

280/281 SERIES

VAPOR / DUST PROOF LIGHTING

DATE: _____	PROJECT MGR: _____
JOB: _____	
CAT#: _____	
TYPE: _____	



Model 280



Model 281

- TASK ①
- PAINTBOOTH ②
- VAPOR DUST ③
- VAPOR ④
- WET DAMP ⑤
- MARINE ⑥
- EXPLOSION PROOF ⑦
- HID ⑧
- INSPECTION ⑨
- PORTABLE LIGHTING ⑩
- MOUNTING ⑪
- PHOTOMETRY ⑫
- LAMPS BALLASTS ⑬
- INFO ⑭
- CUSTOM ⑮
- ASK THE EXPERT ⑯

DESCRIPTION

The 280/281 Series is a product designed specifically for Paint Spray Booths, with a wider fixture design these products will provide increased photometric output and efficiencies. These 4 lamp 8' fixtures are available in wattages including 59, 86, 95 or 110 watts. The 280 Series allows for both Front and Rear access using a paint spray cutoff switch when either front door frame is opened. The 281 Series is a rear access only fixture and does not require paint spray cutoff. Both units carry multiple listings from ETL for Class I Div. 2 & Class II Div. 2 applications. **Must be mounted hinge side up.**

SPECIFICATIONS

- LISTINGS:** ETL listed for U.S. and Canada
 Class I Division 2 Groups A,B,C,D
 T3C (160 degree C) Operating Code
 Class II Division 2 Groups F,G
 T3C (160 degree C) Operating Code
 Listed for locations having deposits of readily combustible paint residues.
- HOUSING:** 20 Gauge steel construction with white baked enamel finish which creates a durable, highly reflective finish. Housing styles for either front and rear accessibility in the Series 280, or rear access only in the Series 281.
- LENS:** 3/16" Clear tempered glass.
- ELECTRICAL:** Paint spray cutoff switch for each front door frame access of the Series 280. Available in 59, 86, 95 or 110 Watts in T8, T8HO, & T12HO lamps. Voltages of 120, & 277 Volts.
- OPTIONS:** **All Options Ordered Separately**
 EM: Emergency Battery Backup Ballast
 120 or 277V **MUST SPECIFY**
 Wire Whip 8 Ft. - 5901: 3-wire (281) or 5902: 5-wire (280)
- **MOUNTING KITS - Ordered Separately** - See Page 11.5
 Panel Stiffner Kit #1728 (fits 18 gauge panels)
- NOTE:** Normally open magnetic switches are intended to be used to trigger a relay (furnished by others) which disables the paint system. Because of the small capacity of the switch, a solid state relay is recommended. It may be desired by others to utilize a separate power supply to segregate the relay (furnished by others) from the lighting power supply. The Magnetic Switch **IS NOT** designed to directly control light operation!
The Magnetic Switch is rated for 10 watts resistive at a maximum of 300 VAC.
- CAUTION:** Overloading the switch circuits **WILL** cause failure. LDPI, Inc. recommends having a certified electrician/engineer review loads to ensure that overloading of switch does not occur.



280/281 SERIES

VAPOR / DUST PROOF LIGHTING

PART NUMBERS

Series	Watt	Lamp Qty	Hub	Order #	Voltage
390280 Front & Rear Access	59W T8	4	1/2" NPT	390280120	3281 120 Volts 60HZ
		4	1/2" NPT	390280277	3534 277 Volts 60HZ
	86W T8HO	4	1/2" NPT	390280UNV	4854 120-277 Volts 50/60HZ
		4	1/2" NPT	390280120	3260 120 Volts 60HZ
	95 or 110W T12HO	4	1/2" NPT	390280277	3222 277 Volts 60HZ
		4	1/2" NPT	390281120	3281 120 Volts 60HZ
390281 Rear Access	59W T8	4	1/2" NPT	390281120	3281 120 Volts 60HZ
		4	1/2" NPT	390281277	3534 277 Volts 60HZ
	86W T8HO	4	1/2" NPT	390281UNV	4854 120-277 Volts 50/60HZ
		4	1/2" NPT	390281120	3260 120 Volts 60HZ
	95 or 110W T12HO	4	1/2" NPT	390281277	3222 277 Volts 60HZ

LAMPS SOLD SEPARATELY
(All Options Ordered Separately)
 Mounting Options - See Page 11.5

DIMENSIONS

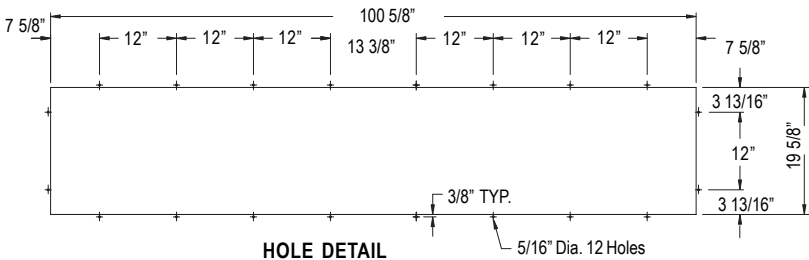
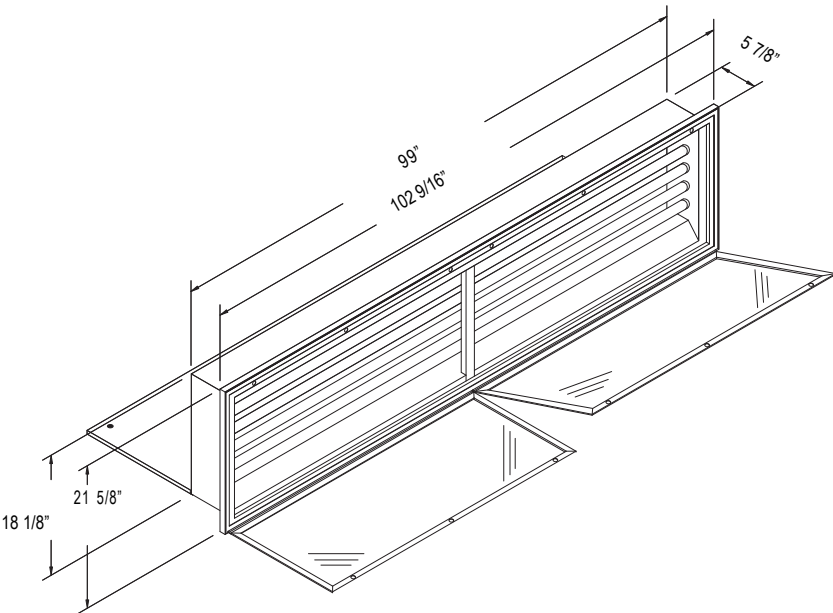

- ① TASK
- ② PAINTBOOTH
- ③ VAPOR DUST
- ④ VAPOR
- ⑤ WET DAMP
- ⑥ MARINE
- ⑦ EXPLOSION PROOF
- ⑧ HID
- ⑨ INSPECTION
- ⑩ PORTABLE LIGHTING
- ⑪ MOUNTING
- ⑫ PHOTOMETRY
- ⑬ LAMPS BALLASTS
- ⑭ INFO
- ⑮ CUSTOM
- ⑯ ASK THE EXPERT

MOUNTING

1-800-637-4027

280/281 Series

PN: 1728 Panel Stiffener and Interlock Switch

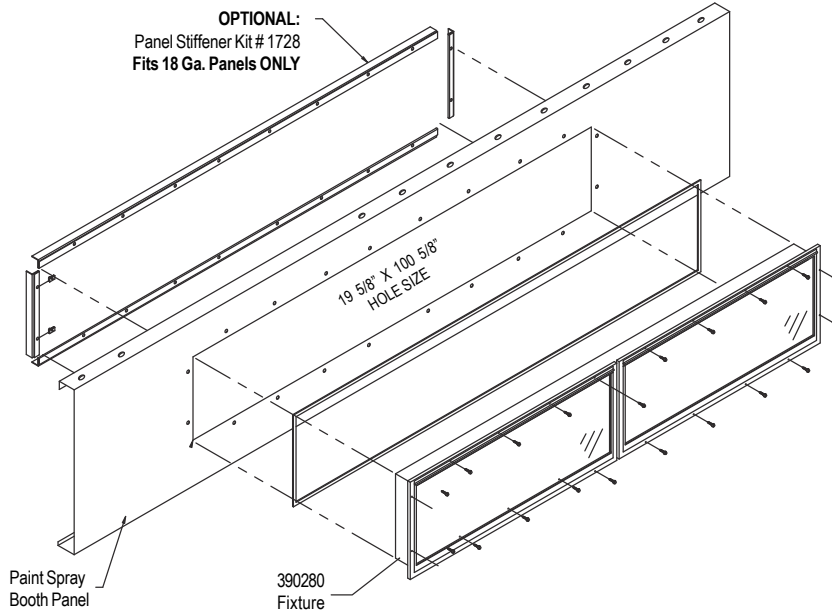

- TASK ①
- PAINTBOOTH ②
- VAPOR DUST ③
- VAPOR ④
- WET DAMP ⑤
- MARINE ⑥
- EXPLOSION PROOF ⑦
- HID ⑧
- INSPECTION ⑨
- PORTABLE LIGHTING ⑩

- MOUNTING ⑪**
- PHOTOMETRY ⑫
- LAMPS BALLASTS ⑬
- INFO ⑭
- CUSTOM ⑮
- ASK THE EXPERT ⑯

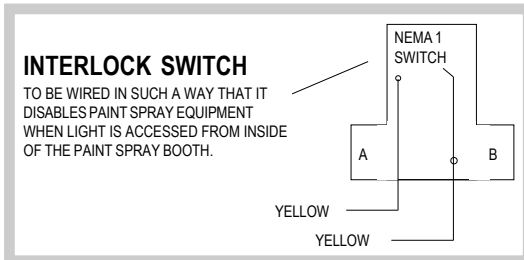
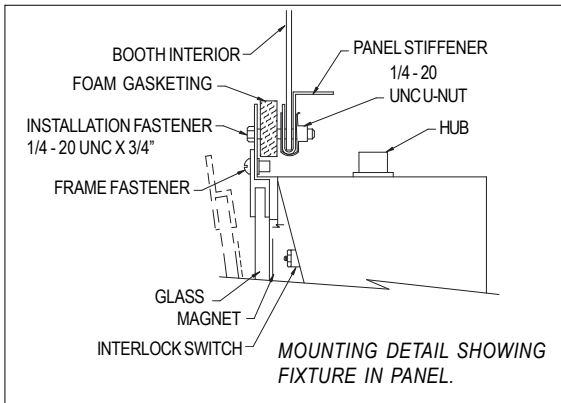

IMPORTANT:

Normally open magnetic switches are intended to be used to trigger a relay (furnished by others) which disables the paint system. Because of the small capacity of the switch, a solid state relay is recommended. It may be desired by others to utilize a separate power supply to segregate the relay (furnished by others) from lighting power supply. **The magnetic switch is rated for 10 watts (resistive) at a maximum of 300 VAC.**

The magnetic switch is **NOT** designed to directly control light operation.

CAUTION: Overloading the switch circuits will cause failure. LDPI® recommends having a certified electrician/engineer review circuit loads to insure that overloading of switch does not occur.

